

## LD-838

### Butterfly Valve -Lever Handle

#### FEATURES:

- Rigid plastic body and disc for dependable chemical resistance inside and out.
- Wafer type disc offers less flow restriction than other designs.
- Face-seal design requires no additional gaskets between mating flanges.
- Ideally suited for flow control using minimal piping space.
- Handle gives clear indication of disc opening degree.

### Válvula de Mariposa -con Manija

#### CARACTERÍSTICAS:

- Cuerpo y disco de plástico rígido para asegurar la resistencia a químicos, tanto interior como exterior.
- El diseño del disco disminuye las restricciones de flujo más que en otros diseños.
- Con diseño de sellado esférico no requiere de otros empaquetaduras entre las bridas.
- Ideales para el control de fluido usando mínimo espacio.
- La manija da clara indicación del grado de apertura del disco.

### Vanne Papillon -Poignée à Levier

#### CARACTÉRISTIQUES:

- Corps et disque plastique rigide pour la résistance chimique fiable intérieur et extérieur.
- Le type de plaquette disque offre un débit extrêmement faible de restriction que les autres modèles.
- Une conception d'un joint d'étanchéité axiaux, sans joint supplémentaire entre les brides.
- L'idée pour le contrôle de flux en utilisant un minimum d'espace tuyauterie.
- La poignée peut être clairement indiquer le degré d'ouverture du disque.

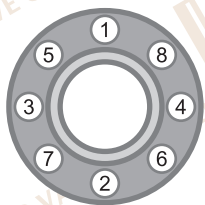
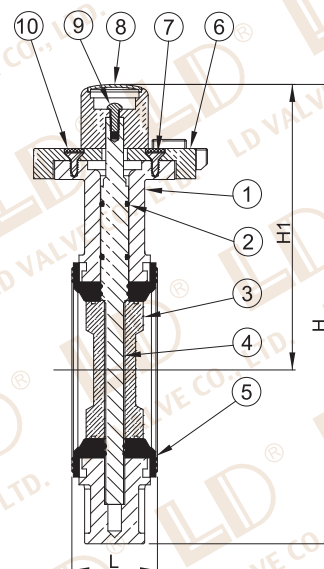
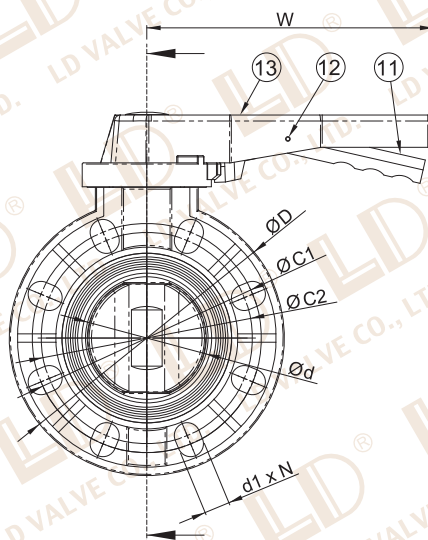
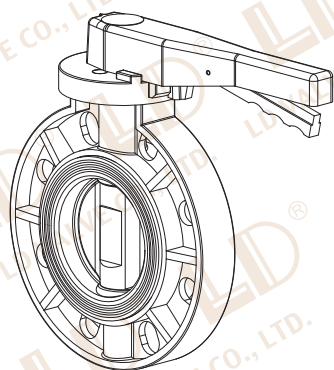

When installing flanges, it is critical that bolts be equally tightened in sequence which diametrically opposed to each other.

Al instalar las bridas, es crítico que los tornillos sean igualmente ajustados en secuencia que debe ser diametralmente opuesto uno al otro.

Lorsque l'installation de bridas, il est essentiel que les boulons sont serrés dans l'ordre de être diamétralement opposés les uns aux autres.

NO	PARTS NAME	MATERIALS	PCS
1	BODY	PVC/CPVC/PP	1
2	O-RING	NBR/EPDM	2
3	DISC	PVC/CPVC/PP	1
4	STEM	STAINLESS STEEL	1
5	GASKET	NBR/EPDM	1
6	INDICATOR PLATE	ABS/PVC/PP	1
7	SCREW	STAINLESS STEEL	4
8	SCREW CAP	ABS/PVC/PP	1
9	SCREW	STAINLESS STEEL	1
10	SCREW CAP	ABS/PVC/PP	4
11	LEVER	ABS/PVC/PP	1
12	PIN	STAINLESS STEEL	1
13	HANDLE	ABS/PVC/PP	1

DN	SIZE	W (mm)	ψ D (mm)	H (mm)	ANSI (mm)		BS (mm)		DIN (mm)		JIS (mm)		WORKING PRESSURE	MASTER CARTON QTY	REMARK
					PCD	HOLES	PCD	HOLES	PCD	HOLES	PCD	HOLES			
50	2"	43	160	220	121	4	114.3	4	125	4	120	4	150PSI@73°F/ PN10bar@22°C		
65	2-1/2"	46	181	246	140	4	127	4	145	4	140	4			
80	3"	49	196	263	152	4	146	4	160	8	150	8			
100	4"	58	230	307	191	8	178	8	180	8	175	8			
125	5"	64	258	370	216	8	209.6	8	210	8	210	8			
150	6"	70	286	400	241	8	235	8	240	8	240	8			
200	8"	88	345	475	298	8	292	8	295	8	290	12			